

- Safety notes:  
Installation should be performed only by qualified electrician .
- Make sure no voltage while installation .
  - Connect cable wires according to wire labeling.
  - Max current should not exceed 16A in one power feed in circuit.

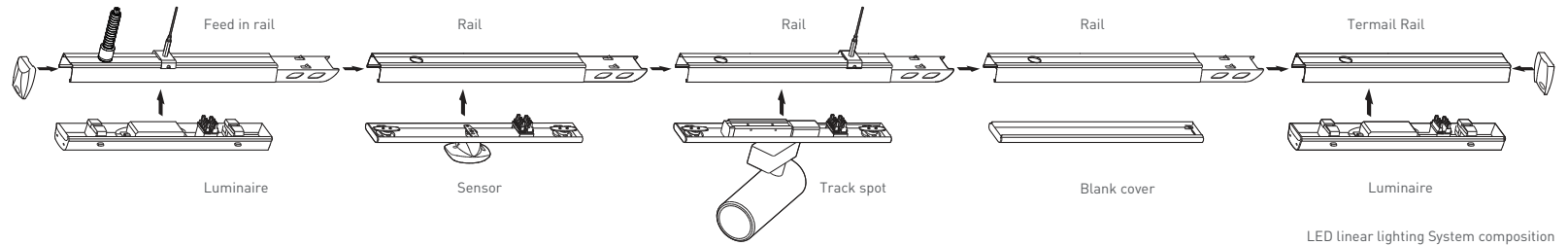

LED linear lighting System composition

## Terminal module:

Terminal module can be independently installed as a single unit, it also can be connected at end of one linear light row.

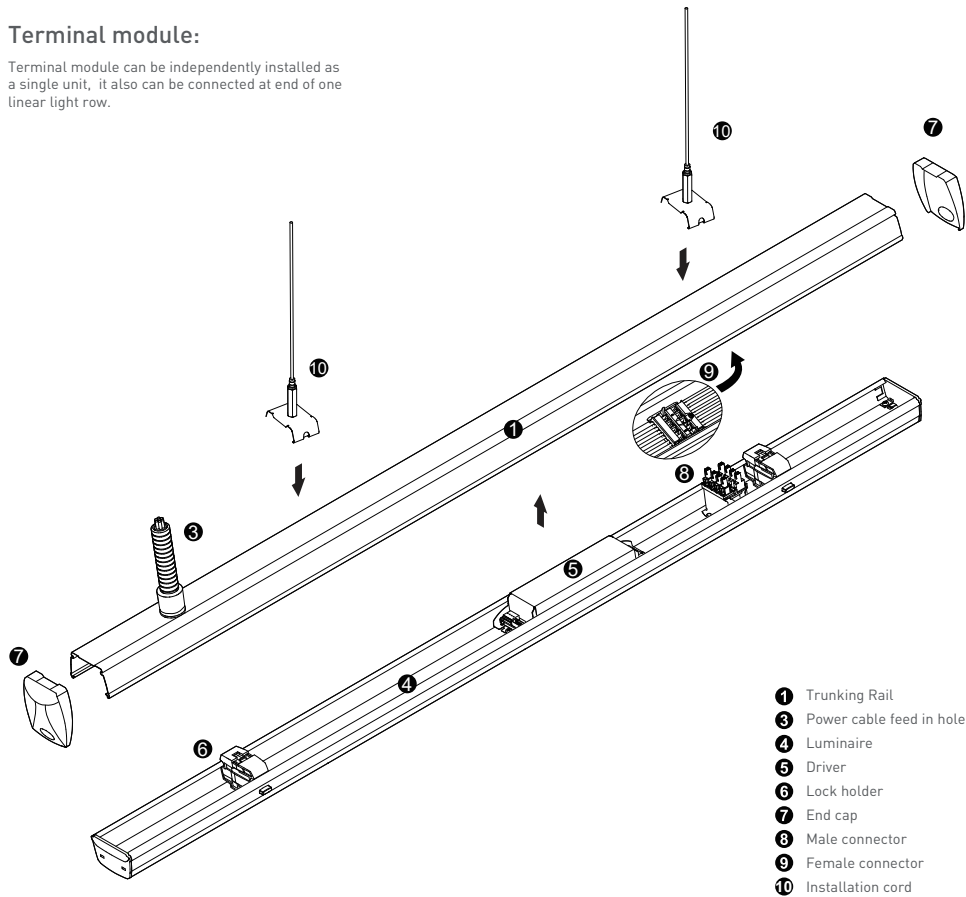

### Step 1

#### Mounting Suspension

Drill a hole on ceiling

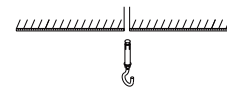

Fix mounting hook into ceiling

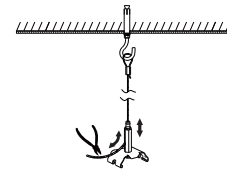
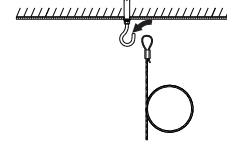

Adjust length of suspension cord:  
a. press down Hexagon bolt;  
b. Pull in/out cord to adjust length

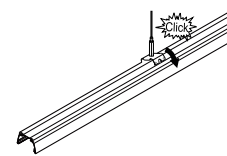

Click in mounting clip into trunking rail

### Step 2

#### Connecting Power Supply



Cut the Rubber cap to pass the power cable



Screw in the conduit gland

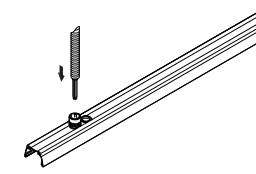

Put in conduit with cable inside and pull up conduit gland to lock

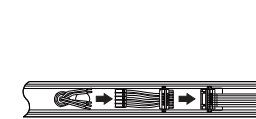

Connect wires according labeling on wires to feed in connector then connect to connector in trunking rail

### Step 3

#### Mounting Luminaire

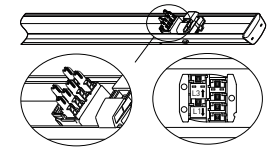

Slide knob to select phase L1/L2/L3

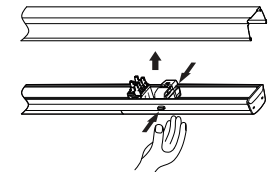

Make sure male & female connectors in right position then fix the luminaire to trunking rail



Push the sliding lock to lock the luminaire to trunking rail

**Tracking and luminaire:**

First trunking rail should have one side connecting plate & last trunking rail with no connecting plate on both sides, then fix the Luminaire to trunking rail then lock holder, then keep end caps at both sides.

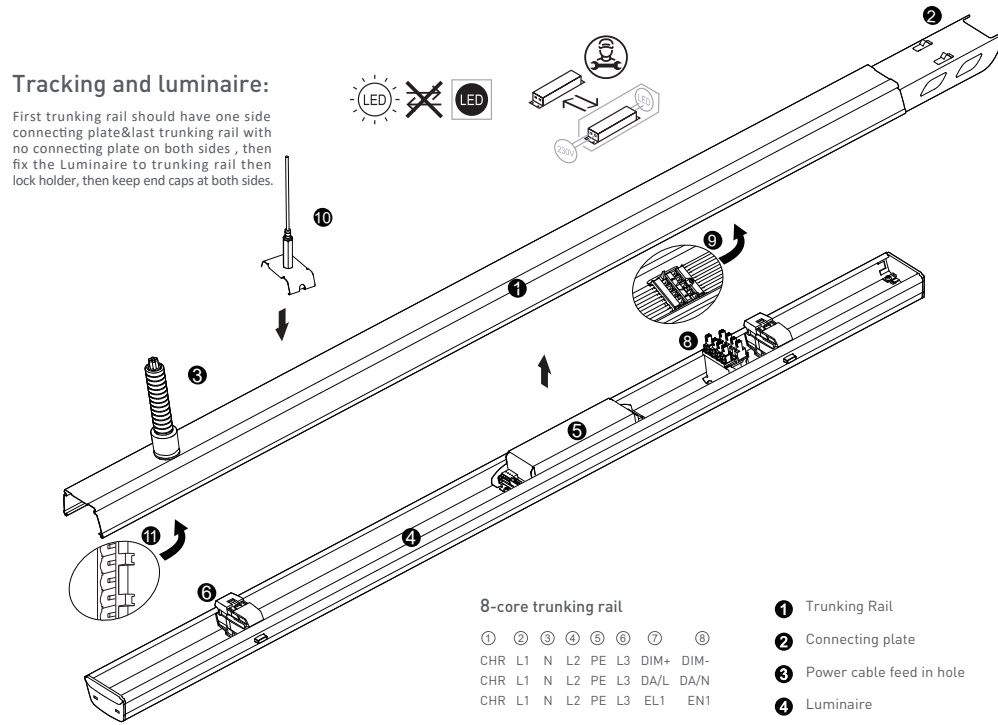

**8-core trunking rail**

①	②	③	④	⑤	⑥	⑦	⑧
CHR	L1	N	L2	PE	L3	DIM+	DIM-
CHR	L1	N	L2	PE	L3	DA/L	DA/N
CHR	L1	N	L2	PE	L3	EL1	EN1

**12-core trunking rail**

①	②	③	④	⑤	⑥	⑦	⑧	⑨	⑩	⑪	⑫
CHR	L1	N	L2	PE	L3	DIM+	DIM-	EL1	EN1	EN2	EL2
CHR	L1	N	L2	PE	L3	DA/L	DA/N	EL1	EN1	EN2	EL2
CHR	L1	N1	L2	PE	L3	DIM+	DIM-	L4	N2	L5	L6
CHR	L1	N1	L2	PE	L3	DA/L	DA/N	L4	N2	L5	L6

**① Definition of 5-core 8-core and 12-core trunking rail**

**5-core trunking rail** ① ② ③ ④ ⑤

L1	N	L2	PE	L3
----	---	----	----	----

- ① Trunking Rail
- ② Connecting plate
- ③ Power cable feed in hole
- ④ Luminaire
- ⑤ Driver
- ⑥ Lock holder
- ⑧ Male connector
- ⑨ Female connector
- ⑩ Installation cord

**Wire diagram of triple circuits function**

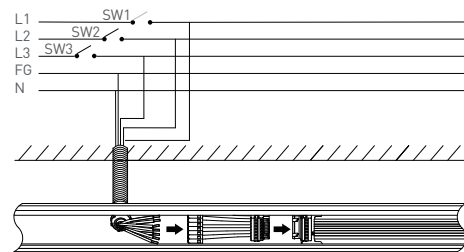

This Triple Circuits function offers to control lighting ON/OFF by three switches SW1, SW2, SW3 which are connected by live lines L1, L2, L3

**Pendant and mounting installation**

Starting Installation distances point should be 800 mm to 1000 mm, then in between 1st & 2nd point should be 3000 mm max

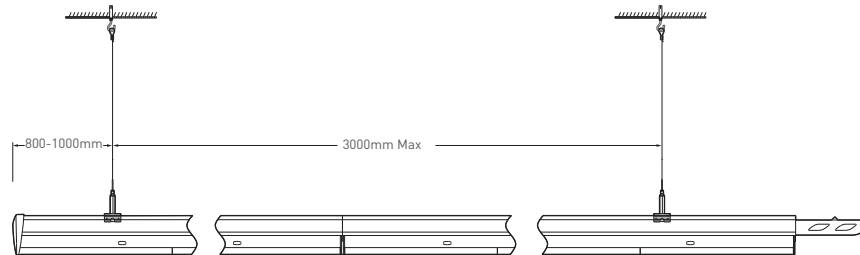

**Four options for installation**

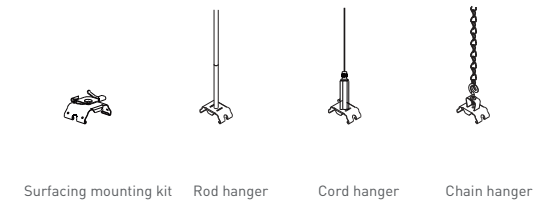

**Step 1**  
**Mounting Suspension**

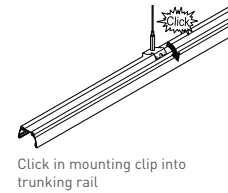
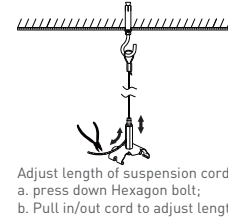

**Step 2**  
**Connecting Power Supply**

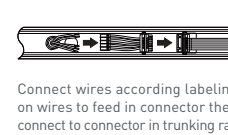
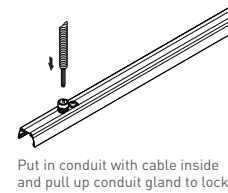

**Step 3**  
**Connecting Trunking Rail**

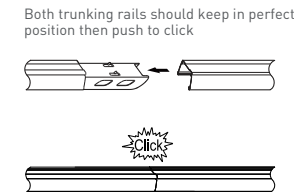

**Step 4**  
**Mounting Luminaire**

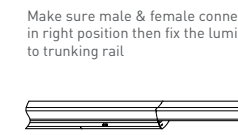
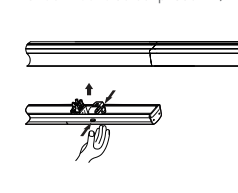
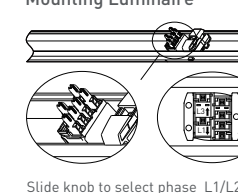

**Step 5**  
**LED linear lighting system**

